

# SUGGESTED CROSSOVER DESIGN

## FTX0820

Coaxial, cast aluminium chassis driver

### Crossover Circuit Diagram

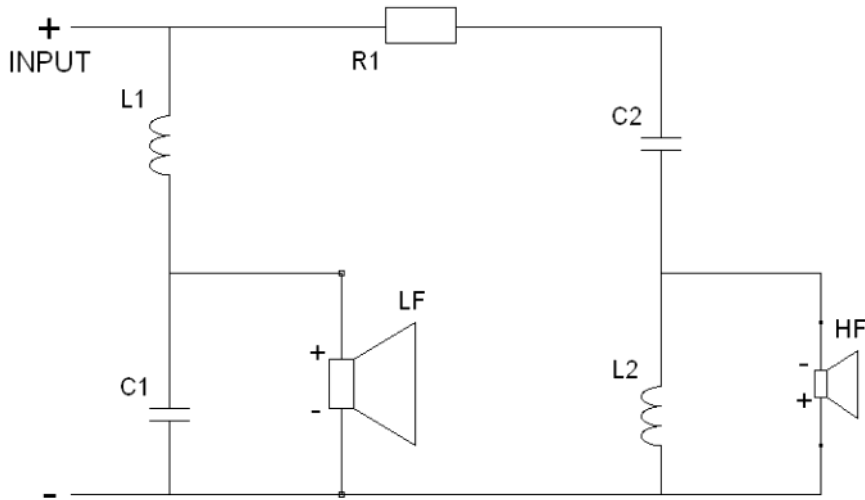

### Crossover Circuit Components

No.	Component	Value	Description	Additional
R <sub>1</sub>	Resistor	12Ω	Ceramic, wirewound	>25W
C <sub>1</sub>	Capacitor	12.0μF	Polyprop, non-polarised	5%>250V
C <sub>2</sub>	Capacitor	4.7μF	Polyprop, non-polarised	5%>250V
L <sub>1</sub>	Inductor	1.6mH	Air-cored	<0.35Ω
L <sub>2</sub>	Inductor	0.25mH	Air-cored	<0.28Ω

### General Driver Specifications

Power rating: LF..... 200Wrms (AES Standard)  
 Power rating: HF..... 40Wrms (AES Standard)  
 Nominal Impedance: LF..... 8Ω  
 Nominal Impedance: HF..... 8Ω  
 Sensitivity: LF..... 94dB  
 Sensitivity: HF..... 103dB  
 Overall frequency response..... 70Hz-20,000Hz  
 Crossover frequency..... 1900Hz

### Suggested Cabinet Alignment

Volume (V<sub>b</sub>)..... 8lt/0.28ft<sup>3</sup>  
 Tuning frequency (F<sub>b</sub>)..... 80Hz  
 Vent diameter (V<sub>d</sub>)..... 60mm/2.4in  
 Vent length (V<sub>l</sub>)..... 100mm/4in

### Driver Mounting Information

Overall diameter..... 225mm/8.86in  
 Overall depth..... 114mm/4.49in  
 Terminal: LF..... Spade, 6.3mm/0.25in  
 Terminal: HF..... Spade, 6.3mm/0.25in  
 Cut-out diameter..... 187mm/7.36in  
 Mounting slot dimensions..... ∅6.5mm/0.26in  
 Number of mounting slots..... 8  
 Mounting PCD range..... 210mm/8.27in  
 Unit weight..... 4.1kg/9.0lb

